LUCOBIT-WATERPROOFING MEMBRANES FOR WATER RESERVOIR, SWIMMING POOLS AND WASTE DISPOSAL



... make better sealing

LUCOBIT-Waterproofing Membranes:

1 Water Reservoir

1.1 General	4
1.2 Recommendation	4
1.2.1 Planning.....	4
1.2.2 Welding.....	5
1.2.2.1 Manual welding.....	5
1.2.2.2 Automatic welding.....	6
1.2.3 Reservoir structure (liner substrate).....	7
1.2.4 Levelling and drainage layer	8
1.2.5 Protective barrier layer	8
1.2.6 Lucobit reservoir liner.....	8
1.2.7 Storage.....	8
1.2.8 Reservoir perimeter.....	8
1.2.9 Flashing.....	9
1.2.10 Flashing above the waterline	9
1.2.11 Flashing below the waterline.....	9
1.2.12 Penetrations	9
1.2.13 General Installation recommendations	9

1.3 Detail Drawings	10
3.1 Reservoir liner with no protective cover	10
3.2 Reservoir liner with protective cover	11
3.3 Reservoir with terraced slope and protective cover.....	12

2 Swimming Pool

2.1 Requirements	14
2.1.1 General.....	14
2.1.2 Requirements for swimming pools	14
2.1.3 Planning.....	14
2.2 System Recommendations	15
2.2.1 Membrane substrate.....	15
2.2.2 Pressure-free drainage	15
2.2.3 Levelling and drainage layer	15
2.2.4 Lucobit waterproofing membrane	15
2.2.5 Storage.....	15
2.2.6 Connections to fittings	15
2.2.7 Perimeter flashing.....	15
2.2.8 Finishing the installation	16
2.2.9 General Installation recommendations	16

2.3 Detail Drawings	16
2.3.1 Intersection at floor and wall	16
2.3.2 Edging with laminated flashing strip.....	17
2.3.3 Edging with laminated flashing strip.....	17
2.3.4 Penetration, flange with champing ring	18
2.3.5 Intersection at sloping floor and wall	18
2.3.6 Change in slope of pool floor	19
2.3.7 Stair surfacing.....	19
2.3.8 Pressure-free drain.....	20
2.3.9 Pressure-free drain (groundwater).....	20

3 Waste Disposal

3.1 Waste Disposal	22
3.1.1 Landfill construction	22
3.1.1.1 Contrep sealing	22
3.1.1.2 Schematic diagram of the base seal	23
3.1.1.3 Landfill surface sealing	23

Water Reservoir



1.1 General

1.1.1 General

Waterproofing for reservoirs has great significance - technically and economically. Not only is the quality of manufactured materials important, but selection and installation of a system that is best suited to the specific requirements of the structure (type of construction, soil conditions, water conditions, etc.). Every reservoir must remain watertight and serviceable for many years. To achieve these goals, LUCOBIT – as designer raw material for membranes for reservoirs – draws upon a vast body of knowledge and experience.

Lucobit waterproofing systems

- enhance the performance of reservoirs
- give the operator better reliability
- are overall economical solutions
- meet applicable waterproofing requirements

The materials we use are developed and tested in our own laboratories, based on the specific requirements of use. All materials have been thoroughly proven in practice.

LUCOBIT, use reliable hot-air welding machines to produce spliced seams that are tested for watertightness with compressed air.

Each waterproofing installation is carefully planned to perfectly suit each structure.

The following describes what possibilities we offer, and what type of performance you can expect.

Our technical consultant and engineers will help develop a waterproofing solution perfectly suited to your structure.

1.1.2 Reservoir liners must meet these requirements

- The liner must stand up to adverse treatment during installation and use. It must guarantee long-lasting watertightness.
- The liner must be easy and economical to install, especially considering the difficult conditions involved in constructing reservoirs.
- The waterproofing membrane must have good ageing characteristics. The material must be resistant to fluctuations in temperature and water level.
- Welded seams must provide permanent watertightness. Reliable welding methods should be used, mechanised as much as possible.

All these criteria were fully by our products for reservoir liners. During planning, installation, and use, you will be convinced.

1.2 Recommendation

1.2.1 Planning

Reservoirs lined consist of two basic systems: the structure itself (foundation soil/prepared substrate surface) and the waterproofing liner.

The selection and design of the best waterproofing system for a specific reservoir depends on many factors:

Reservoir shape

- geometry of the reservoir (rectangular, round, elliptical, etc.)
- slope of the sides
- terracing of the slope

Suitability for traffic

- protective cover

Soil characteristics

- possible settlement
- stable soil
- special characteristics

Water flow

- standing water
- flowing water

Water level

- constant
- strongly fluctuating

Geographic situation

- ice formation
- temperature conditions
- wind conditions

Accessibility

- easy accessibility
- difficult accessibility, e.g. an industrial site

Cleaning method

- by machine
- by hand

Environmental requirements

- regulations
- guidelines / standards

Choosing the best material depends on the relative importance of these different factors for each specific reservoir.

If the reservoir includes steep slopes, safety barriers must be installed, such as fences for man and animal.

Building the best reservoirs requires the following:

- Careful planning (including detail drawings)
- Early selection of the waterproofing system and materials
- Detailed specifications for offers from installers
- Installation of the waterproofing system by qualified specialists only
- Co-ordination and monitoring of the waterproofing work

Reservoir liner systems should be planned by professionals and installed only by specialised waterproofing companies. This is your assurance that your reservoir will remain functional and watertight for years to come.

1.2.2 Welding

Practical training is necessary!

1.2.2.1 Manual welding

a) Instructions

Turn on a hand-held welder and check the temperature (approx. 450-500°C). Welding of Lucobit® and Lucofin® sealing membranes is done in two steps: Turn on a hand-held welder and check the temperature (approx. 450-500°C). Welding of Lucobit® and Lucofin® sealing membranes is done in two steps:

1. The upper membrane is tacked onto the lower membrane in the overlap area about 5 (11) cm from the edge. Initial adhesion along one line (and not just at isolated spots) is achieved by pressing against the edge with a silicon roller. This procedure ensures that the proper temperature is maintained in the welding area for the subsequent welding process. Moreover, it ensures faultless positioning of the seal joint.

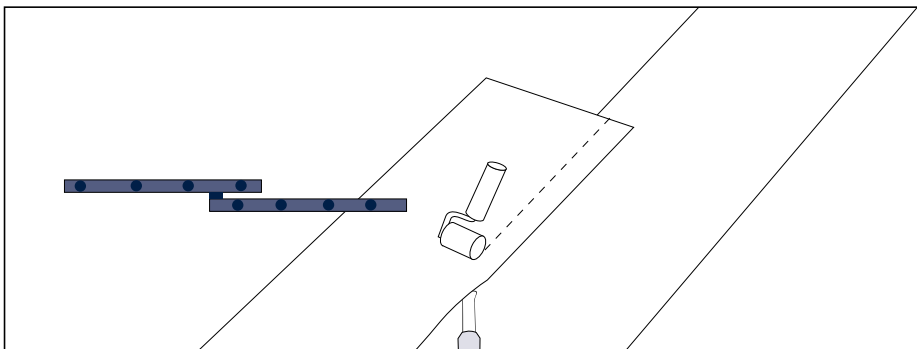
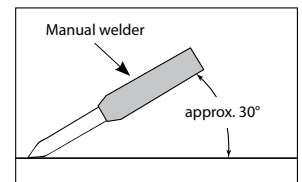

Tacking



Tacking

2. Welding is then carried out over a width of about 4 cm. The welding unit and pressure roller are continually moved in the welding direction so that both surfaces of the seam are heated evenly and bonded uniformly with the pressure roller.

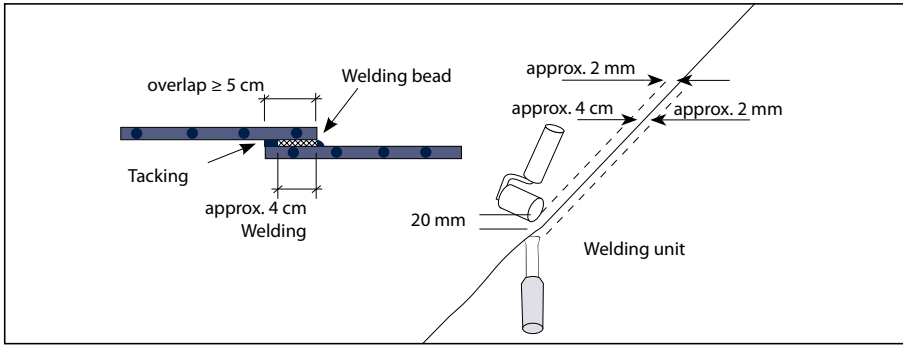

Seam welding



Seam welding

b) Seam bonding

If done correctly, the welding bead along the seam will reflect an optimum joint. After the work is completed, switch off the welding unit heater. To protect the heating elements, however, the blower has to continue running until no more warm air comes out of the nozzle (see 4.1).

1.2.2.2 Automatic welding

Turn on the automatic welder and check the temperature (approx. 450-600°C). Automatic welding is carried out in one step, since the air partitioning on the automatic welder eliminates the need for preliminary tacking. Welding speed is adjustable and determined by the temperature of the surroundings. Welding takes place over a width of around 5 cm. The welding bead along the seam is a visible indication that welding has been carried out correctly. The welding bead should not exceed 1 mm. (see 4.1) See the manual welding instructions (4.2.1) for the procedure after the work is completed.



1.2.3 Reservoir structure (liner substrate)

The earthen reservoir structure (foundation soil/prepared substrate surface) must agree with the plans, especially the incline of slopes and the elevations of terraces. The surface must be free of roots and stones.

Levelling mats are laid directly on the smooth, well-rolled (and compacted, if necessary) top course of the foundation surface. If modelling the soil is difficult due to low cohesion, the soil can often be improved by adding fines. Crushed material is not suitable as a top course. The levelling mats must form a smooth surface and provide continuous support of the waterproofing membrane.

These rules of thumb for reservoir surfaces have been proven in practice:

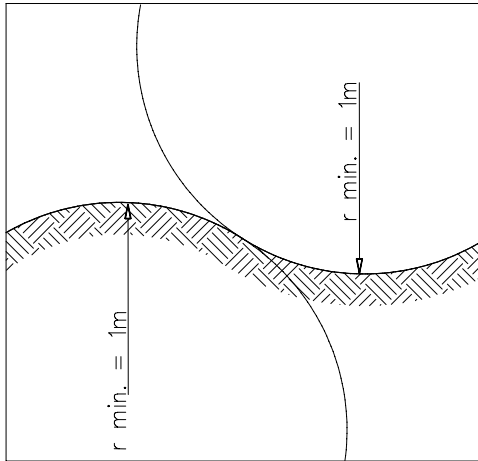

Mounds and hollows:
minimum radius = 1 m

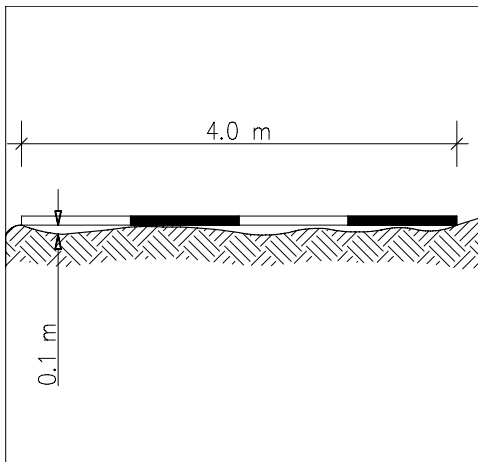

Out-of-plane under a 4 m rod:
maximum 10 cm

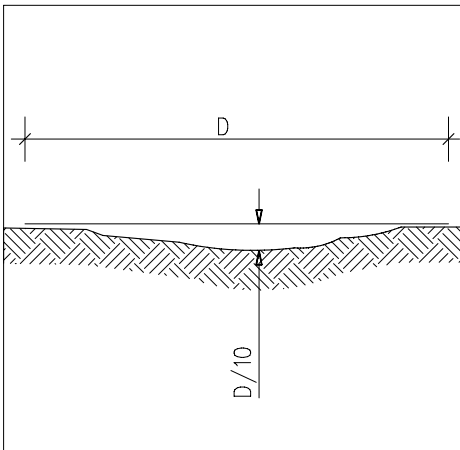

Slow settlement:
 maximum depth = 1/10 of settlement
 diameter D

The reservoir structure (foundation soil/smoothed substrate surface) must be prepared (with additional compaction if necessary) so that no overloading of the waterproofing membrane will occur under water pressure.

Important:

The foundation structure (prepared substrate surface) must be checked before the waterproofing contractor begins his work. Acceptance of the **foundation structure** must be officially recorded in a report.

1.2.4 Levelling and drainage layer

In addition to the well-rolled foundation structure (prepared substrate surface), watertightness is also ensured by the levelling and drainage layer. A geotextile mat weighing at least 500 g/m² is used for this intermediate layer. The layer smoothes out slight unevenness and protects the polymeric membrane from mechanical damage. The selection and properties of the geotextile mat depend largely on the foundation structure.

1.2.5 Protective barrier layer

A protective barrier and slip sheet is required beneath protective coatings such as ballast or cementitious screed. GK fleece (400 g/m²) with PE coating, or a protective membrane made of recycled material may be used. All lap splices in this layer should be adhered (or hot-welded if possible) to seal out cement slurry.

If ballast (such as pavers or rounded gravel) will be placed as a cover or protective layer, the waterproofing membrane must be covered with a geotextile weighing at least 800 g/m² or a suitable protective membrane made of recycled material.

The choice of protective cover basically depends on local factors and specified requirements.

1.2.6 These membranes made of Lucobit® (ECB)/ Lucofin® (FPO-PE) raw material

The line is weather resistant and does not rot. It has high puncture resistance as well as broad chemical stability. It is protected against infestation by microorganisms. This membrane also has an outstanding eco-profile. These membranes contain no fungicides, heavy metals, or plasticizers.

Membranes are loosely laid over the levelling layer. Seams are lapped 8 to 10 cm and hot-air welded. The layout of the sheets is planned to minimise welded seams. Sometimes it is necessary to adhere the sheets due to technical reasons.

1.2.7 Storage

The membranes should be stored on the job site protected from weather. Stored properly, membranes stay dry and clean, keeping seam preparation to a minimum.

1.2.8 Reservoir perimeter

As construction progresses, the perimeter anchor should be promptly concreted or backfilled.

The perimeter anchor should have the following minimum dimensions:

- footing width: 50 cm
- surface width: 50 cm
- depth: 50 cm

The perimeter anchor should be backfilled with soil that is free of stones and roots, or filled with lean concrete, and compacted. The liner is temporarily held in place by reinforcing bars with welded steel plates on the ends.

1.2.9 Flashing

There are two classes of flashing: connections that are subject to hydrostatic pressure and connections that are not. Choosing the right flashing detail depends on this distinction and also on the applicable standards.

Perimeter flashing with flat profiles or clad metal flashing strips is merely a perimeter termination, not a watertight seal. Thus these flashing systems should be used only above the maximum water level.

1.2.10 Flashing above the waterline (no hydrostatic pressure)

As construction progresses, the perimeter anchor should be promptly concreted or backfilled.

- Mechanical connection with a flat profile:
flat profile 30 x 4 mm
- Mechanical connection clad metal flashing strips

1.2.11 Flashing below the waterline (under hydrostatic pressure)

As construction progresses, the perimeter anchor should be promptly concreted or backfilled.

- Membrane welded to an extruded seal:
This type of perimeter flashing uses an extruded seal installed in the forms before concreting. The butt joints between seal sections must be welded watertight when they are installed.

To ensure watertightness, the extruded seals must be fully and properly anchored in the concrete (no air pockets, gravel pockets, etc.). Watertight concrete construction is a requirement for this flashing system. The membrane is heat welded to the extruded seal. The membrane provides extruded seals for inside and outside corners, as well as other preformed shapes.

1.2.12 Penetrations

Pipe penetrations should be executed according to applicable national recommendations and standards.

The following is a summary of relevant requirements of the standard DIN 18195.

- **Pipe penetrations with a clamp flange**
Underwater pipe penetrations more than 1.00 m below the maximum waterline must be executed with a clamp flange (two-piece: fixed flange and outer ring).
- **Pipe penetrations with hose clamps**
Underwater pipe penetrations less than 1.00 m below the maximum waterline may be executed with pipe collars.

Each penetration must be secured with two hose clamps, with bolts offset. A filling of sealant should be applied between the hose clamps.

- **Pipe penetrations with a clamp flange according to DIN Standard 18195**
Underwater pipe penetrations must be executed with a clamp flange (two-piece: fixed flange and outer ring).
- **Pipe penetrations with hose clamps (not covered in DIN Standard 18195)**
Pipe penetrations above the maximum waterline may be executed with pipe collars.

Each penetration must be secured with two hose clamps, with bolts offset.

1.2.13 General Installation Recommendations

Refer to this Installation Guidelines for detailed recommendations on installation.

A test weld should be carried out every day to determine the exact welding parameters.

1.3 Detail Drawings

1.3.1 Standard construction

Reservoir liner with no protective cover

A slope of 1:2 is the maximum for reservoirs with no protective cover. No vehicles may be driven on the exposed membrane.

Never leave a reservoir without a protective layer empty.

Exposed liners must be constantly secured against wind uplift.

During construction, each day's work should be secured against wind uplift.

To allow continuous operation of hot-wedge welders, changes in plane must be rounded with a radius of at least 1 meter.

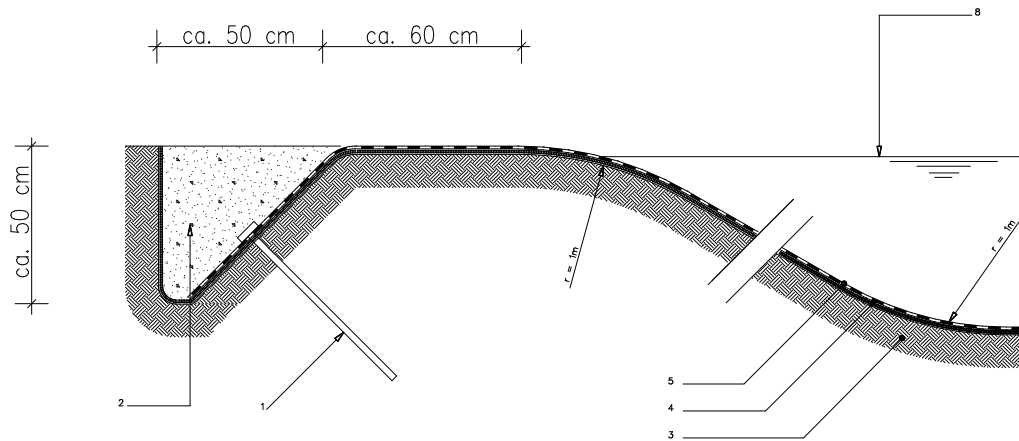

- 1 spike made of reinforcing bar (\varnothing min. 10 mm) with steel plate (min. 100 x 100 mm) welded on end
- 2 perimeter anchor backfilled with soil (free of stones and roots) or sand (0/8 mm), or filled with lean concrete, and compacted
- 3 reservoir structure (foundation soil/prepared substrate surface)
- 4 levelling layer: fleece (500 g/m²) or heavier
- 5 membranes
- 6 maximum waterline.

1.3.2 Standard construction Reservoir liner with protective cover

A slope of 1:3 is the maximum for parts of reservoirs with a protective cover. A protective cover always requires an appropriate protective and barrier layer.

No vehicles may be driven on the unprotected membrane during the construction phase.

During construction, each day's work should be secured against wind uplift.

To allow continuous operation of hot-wedge welders, changes in plane must be rounded with a radius of at least 1 meter.

One layer

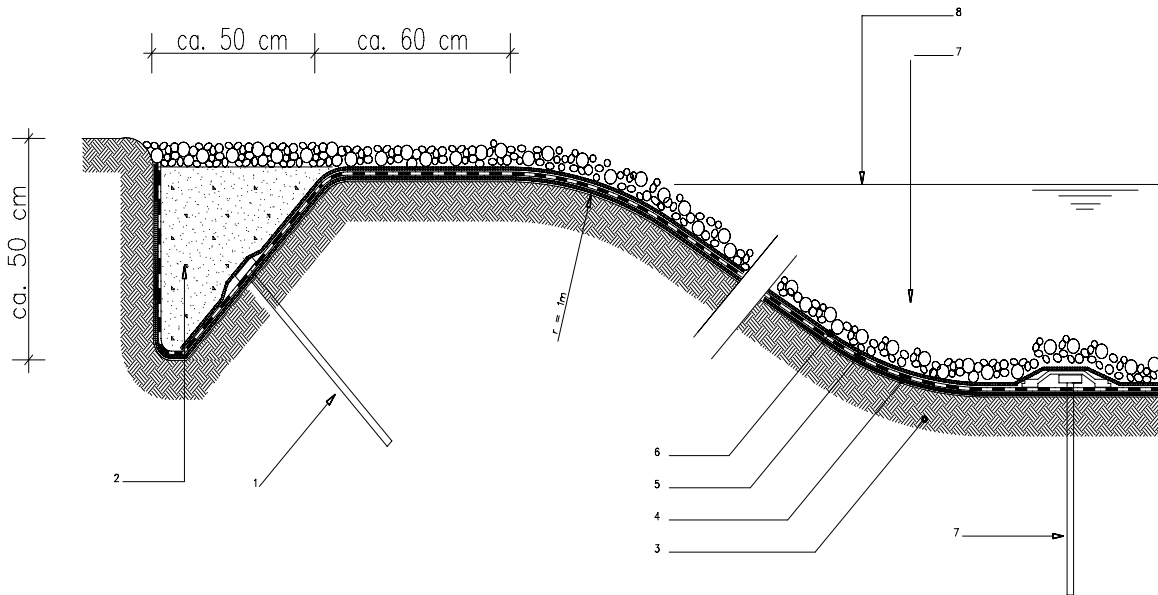

- 1 spike made of reinforcing bar (\varnothing min. 10 mm) with steel plate (min. 100 x 100 mm) welded on end
- 2 perimeter anchor backfilled with soil (free of stones and roots) or sand (0/8 mm), or filled with lean concrete, and compacted (depth 50–60 cm)
- 3 reservoir structure (foundation soil/prepared substrate surface)
- 4 levelling layer: fleece (500 g/m²) or heavier
- 5 membranes
- 6 protective layer: fleece (800 g/m²) or heavier
- 7 ballast
- 8 maximum waterline

1.3.3 Standard construction

Reservoir with terraced slope and protective cover

A slope of 1:3 is the maximum for parts of reservoirs with a protective cover. A protective cover always requires an appropriate protective and barrier layer.

No vehicles may be driven on the exposed membrane.

Never leave a reservoir with a partial protective layer empty. Exposed liners must be constantly secured against wind uplift.

During construction, each day's work should be secured against wind uplift.

To allow continuous operation of hot-wedge welders, changes in plane must be rounded with a radius of at least 1 meter.

Width of terrace bench: min. 1 meter

One layer

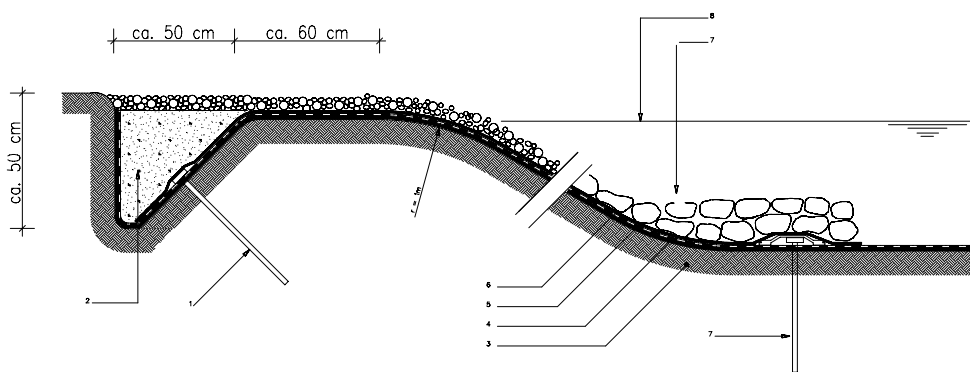

Double layer

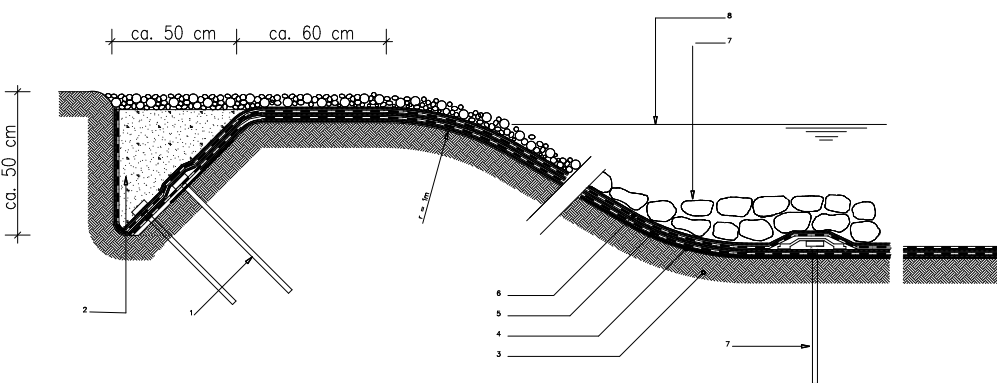

- 1 spike made of reinforcing bar (\varnothing min. 10 mm) with steel plate (min. 100 x 100 mm) welded on end
- 2 perimeter anchor backfilled with soil (free of stones and roots) or sand (0/8 mm), or filled with lean concrete, and compacted (depth 50–60 cm)
- 3 reservoir structure (foundation soil/prepared substrate surface)
- 4 levelling layer, fleece (500 g/m²) or heavier
- 5 membranes
- 6 protective layer, fleece (800 g/m²) or heavier
- 7 spike made of reinforcing bar (\varnothing min. 10 mm) with steel plate (min. 100 x 100 mm) welded on end, plate sealed with a welded membrane cover
- 8 ballast
- 9 maximum waterline

Swimming Pools



2.1 Requirements

2.1.1 General

Every swimming pool owner demands top quality of his pool. Not only must the pool remain watertight for many years, it should also look attractive.

2.1.2 Waterproof in membranes for swimming pools must satisfy these requirements

- The liner must stand up to rugged treatment during installation and use. It must guarantee long-lasting watertightness.
- The liner must be easy and efficient to install.
- The finished pool must be attractive.
- The waterproofing membrane must have good ageing characteristics. The material must be compatible with the standard water-conditioning agents and systems.
- The membrane must be easy to clean and maintain.

All these criteria were fully considered as we developed the membrane made by LUCOBIT raw materials specifically for swimming pools. During application, and during use, you will be convinced.

2.1.3 Planning

A perfectly functioning swimming pool requires all of the following:

- Careful planning (including detail drawings)
- Early selection of system and materials
- Detailed specifications for tenders
- Installation exclusively by specialised waterproofing experts
- Co-ordination and monitoring of the construction work
- Periodic maintenance and cleaning

The membranes includes the following elements:

- Membrane substrate (the pool structure, existing or new construction)
- Pressure-free drainage
- Levelling and drainage layer
- polymeric waterproofing membrane
- Connections to fittings
- Perimeter flashing

Swimming-pool membranes must be planned by experts and installed by specialised waterproofing companies. This ensures that your pool will look good and perform well for years to come.

2.2 System Recommendations

2.2.1 Membrane substrate

The pool structure must be properly designed to carry all loads and hydrostatic pressure. Deformation and settlement of the structure can lead to damage of the swimming-pool liner.

The substrate must be clean, smooth, and free of projections and gravel pockets. Any unevenness or grout from previous tile cladding must be smoothed out. Before beginning application of the membrane, the installer must inspect and accept the substrate.

2.2.2 Pressure-free drainage

A pressure-free drainage system must be installed to carry away any water that might accumulate behind the membrane (for example, migrating water or condensation). The drain holes (minimum 20 mm diameter) should be located near the pool drain and/or at the lowest point of the pool. The number of holes depends on the pool size. If groundwater is present, the pool will require special construction measures. Specific recommendations of the planner or waterproofing expert must be followed. If water becomes trapped behind the membrane and is not removed, gaseous sulphur can form. The gas can diffuse through the polymeric waterproofing membrane and react with metals in the water. This produces dark metal sulphides that deposit on the membrane surface. Metals are introduced into the swimming-pool water by water-conditioning agents or metallic piping.

2.2.3 Levelling and drainage layer

A 400g/m² white polyester mat is applied as a levelling and drainage layer. It smoothes out slight unevenness of the substrate and protects the polymeric waterproofing membrane against mechanical damage. The levelling and drainage layer does not substitute proper substrate preparation as described above. With the drainage action of membranes, groundwater or condensation can migrate to the lowest point, where it is carried off by the pressure-free drainage system. Membranes adhered directly to the prepared pool structure with an adhesive. Seams are butted (not lapped) to provide a neat appearance of the membrane that will follow.

2.2.4 Lucobit waterproofing membrane

Membranes has a long life expectancy and does not rot. It is resistant to a broad range of chemicals and is treated against infestation by micro-organisms. This waterproofing membrane also has an outstanding eco-profile. This membrane is free of fungicides, heavy metals, and plasticizers.

The sheet is loose-laid one at a time over the levelling layer. Seams are lapped 8 to 10 cm and hot air welded. Workmanship and the method of installation must meet high standards of finished appearance.

The membrane sheets are to be laid out in a pattern that minimises seams. Usually the walls are covered first.

Then the floor is covered, the membrane welded to the wall membrane.

At the intersections between floor and wall a cove with radius of 2 to 3 cm should be provided.

At corners, intersections, and spotfastening points the membrane is welded or tack-welded to previously installed membrane-laminated flashing strips. The strips are normally butt-jointed and fastened to the substrate with rustproof impact anchors. Care must be taken that no sharp edges or corners protrude that could damage the membrane. The impact anchors should be sunk flush with the flashing strip so that anchor heads do not show through the membrane once it is applied.

If the membrane must be adhered instead of welded for technical reasons, special adhesive must be used.

2.2.5 Storage

Membranes must be stored dry and protected from weather on the building site. By keeping the membrane clean and dry, seam preparation can be kept to a minimum.

2.2.6 Connections to fittings

Special care must be given to perfectly sealing the membrane around all penetrations (inlet nozzles, skimmers, fasteners, mounts, etc.). All connections must use a stainless steel flange with clamping ring. Locally applicable standards and guidelines are to be observed, acc. DIN 18195. The flange must be set flush in the concrete so that a watertight connection can be executed in the same plane as the membrane.

2.2.7 Perimeter flashing

Perimeter edging is executed using membrane-laminated flashing strips. The flashing strips must be formed to match the specific perimeter detail and then fastened to the pool structure. The edge is finished by welding the membrane over the flashing strips.

2.2.8 Finishing the installation

Final cleaning:

Once the installation is complete, the entire membrane surface is to be thoroughly cleaned with water and sponge or cloth.

2.2.9 General Installation Recommendations

Detailed recommendations for applying membranes are given in the Installation Guidelines.

A trial seam should be carried out at the beginning of each day to determine the exact welding parameters.

Layout lines and measuring marks are to be drawn using an extra-fine ballpoint pen. Markings must **always** be removed before welding. Pencil and felt-tipped pens are not suitable.

Objects that leave unsightly scuff marks on the membrane are to be avoided, including shoes with black soles, black electrical cords, etc.

When laying the membrane, care must be taken that no buckling occurs. Glossy surfaces at seams can easily be dulled by rubbing with a clean dry cloth.

2.3 Detail drawings

2.3.1 Intersection at Floor and Wall

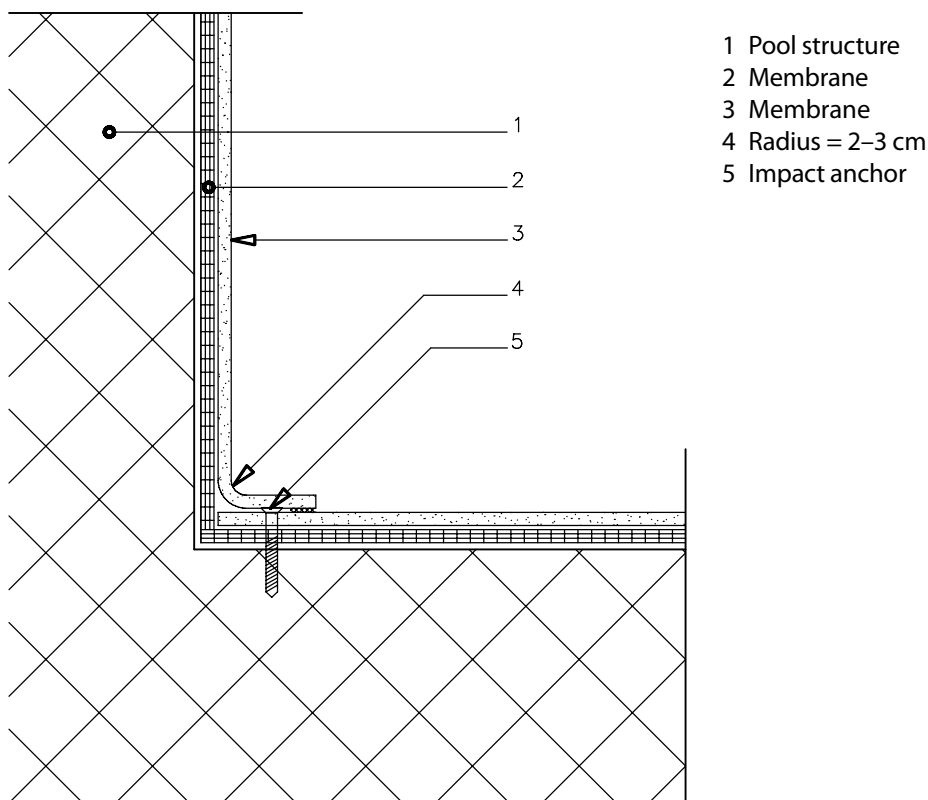

2.3.2 Edging with Laminated Flashing Strip

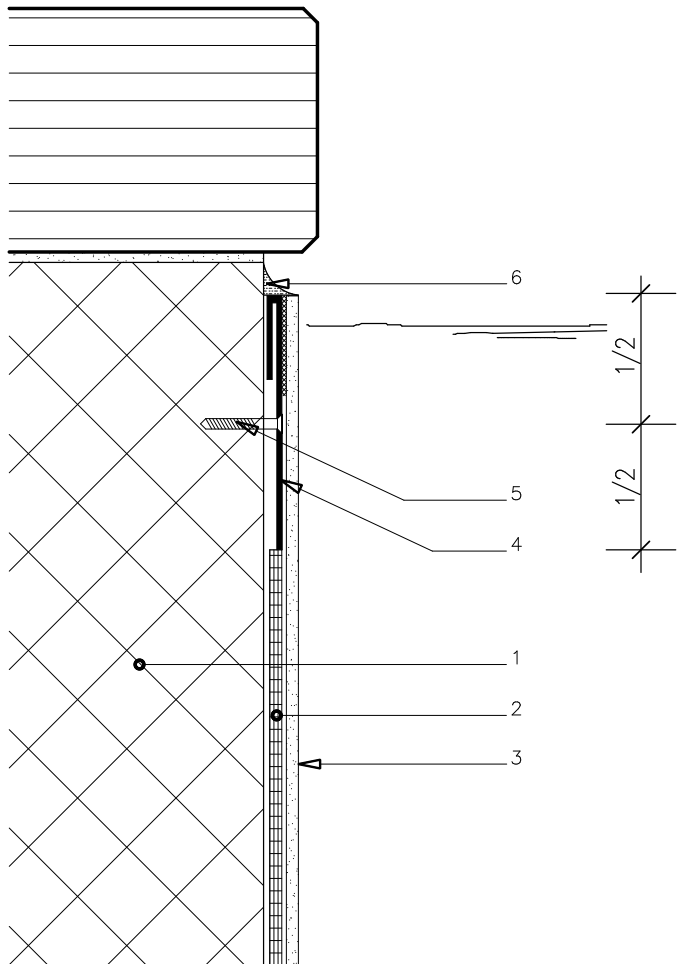

- 1 Pool structure
- 2 Membrane
- 3 Membrane
- 4 Lucobit laminated metal flashing strips
- 5 Impact anchor
- 6 Bed

2.3.3 Edging with Laminated Flashing Strip

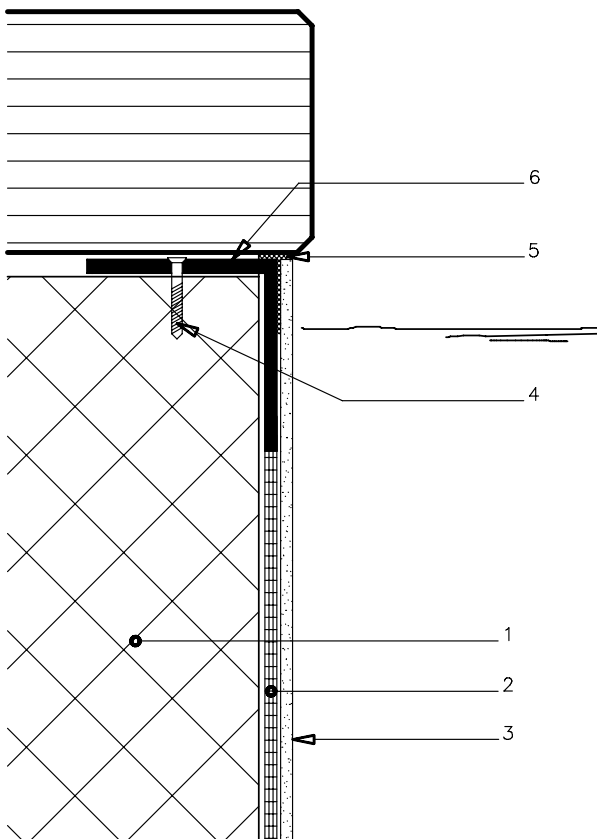

- 1 Pool structure
- 2 Membrane
- 3 Membrane
- 4 Impact anchor
- 5 Bed
- 6 Laminated metal flashing strips

2.3.4 Penetration, Flange with Clamping Ring

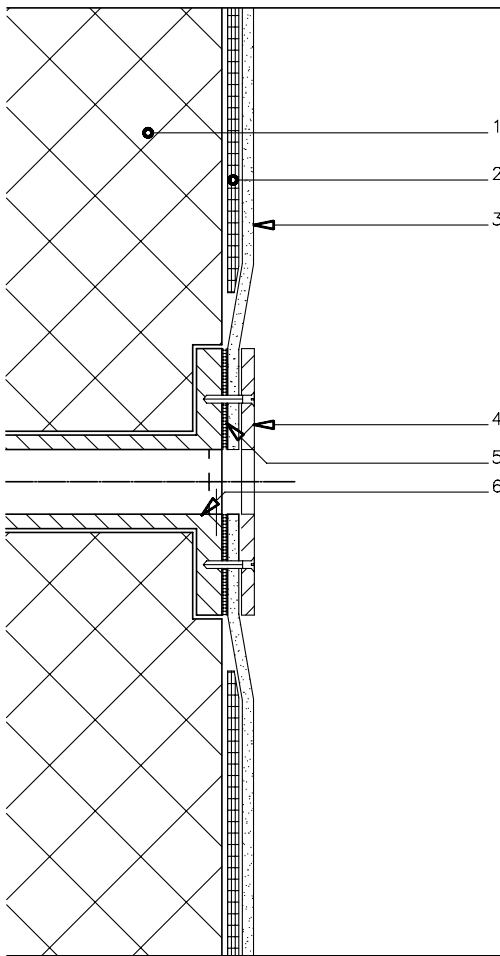

- 1 Pool structure
- 2 Membrane
- 3 Membrane
- 4 Clamping ring
- 5 Sealed with Lucofin® raw material
- 6 Flange (set flush in the concrete)

2.3.5 Intersection at Sloping Floor and Wall

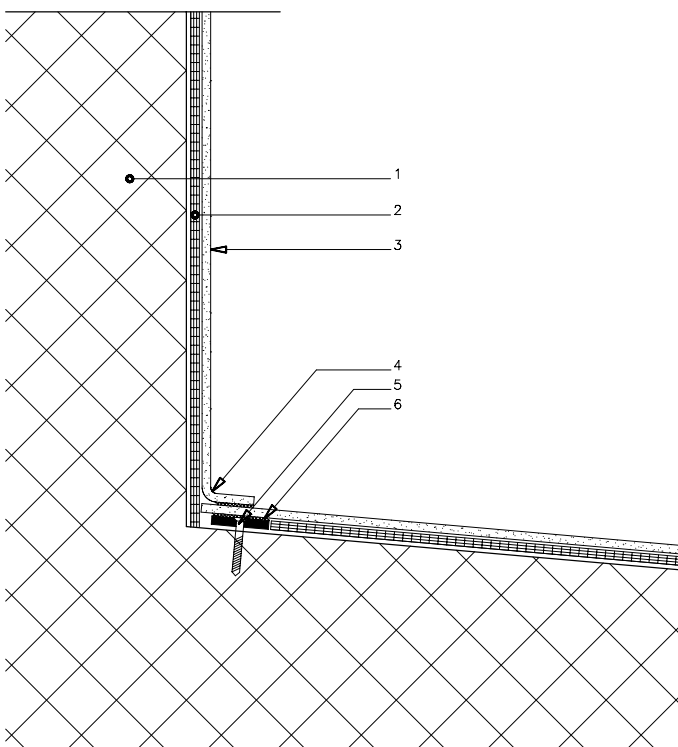

- 1 Pool structure
- 2 Membrane
- 3 Membrane
- 4 Radius = 2-3 cm
- 5 Impact anchor
- 6 Laminated metal flashing strips with Lucofin® raw material

2.3.6 Change in Slope of Pool Floor

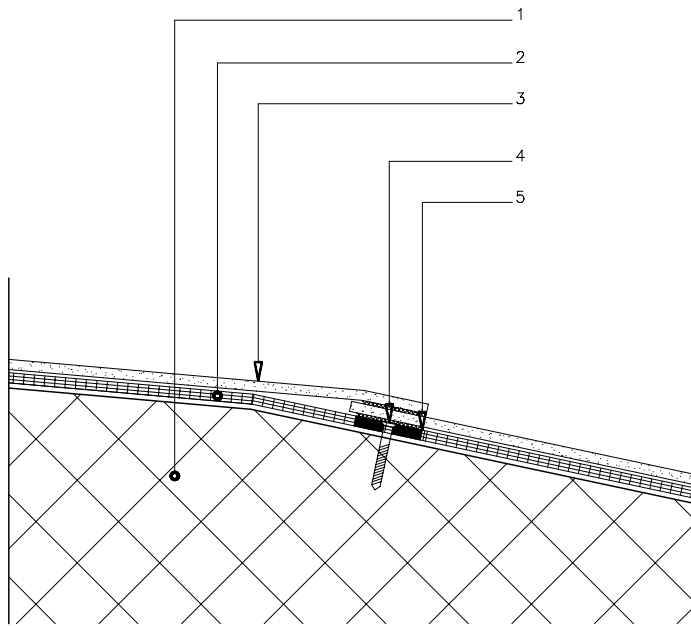

- 1 Pool structure
- 2 Membrane
- 3 Membrane
- 4 Impact anchor
- 5 Laminated metal flashing strips with Lucofin®

2.3.7 Stair Surfacing

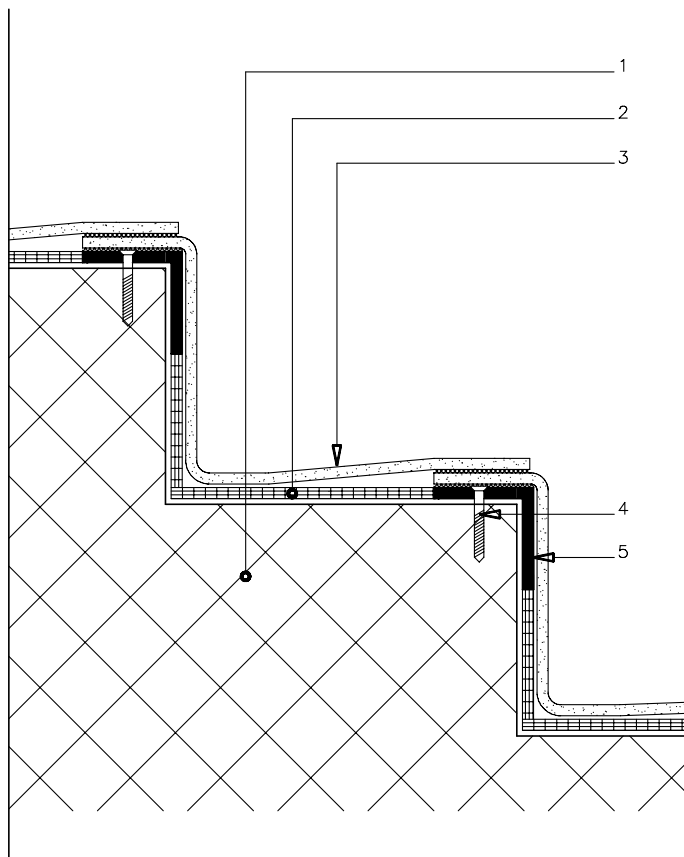

- 1 Pool structure
- 2 Membrane
- 3 Membrane
- 4 Impact anchor
- 5 Laminated metal flashing strips with Lucofin®

2.3.8 Pressure-Free Drain

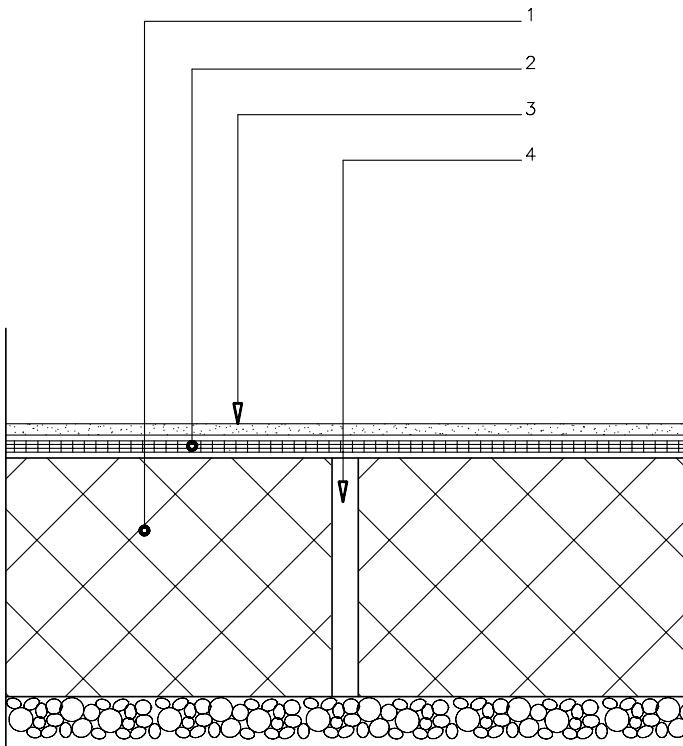

- 1 Pool structure
- 2 Membrane
- 3 Membrane
- 4 Drain hole, minimum 20 mm diameter

2.3.9 Pressure-Free Drain (Groundwater)

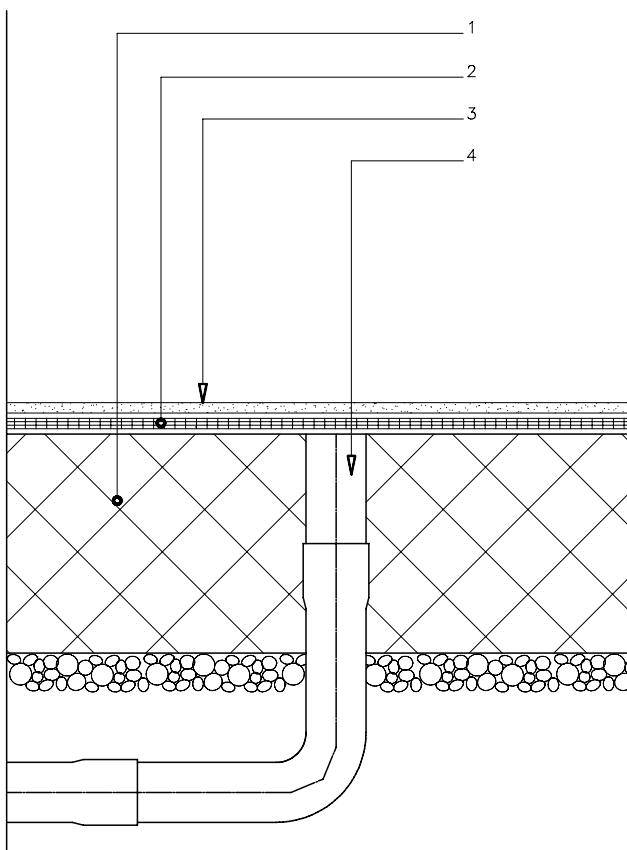

- 1 Pool structure
- 2 Membrane
- 3 Membrane
- 4 Pressure-free drainage with pipes

Waste Disposal



3.1 Waste Disposal

3.1.1 Landfill construction

As basic sealing above the geological barrier for hazardous waste landfills, Germany's "TA-Abfall" (technical instructions on waste management) recommends a combination seal consisting of a 2.5 mm thick plastic sealing membrane pressure-moulded to a mineral seal. In the long run, chlorinated hydrocarbons can permeate through plastic sealing membranes. The permeation rate for HDPE plastics is particularly low, tending toward zero when used in a combination seal. The Contrep® sealing system goes beyond the requirements specified in "TA-Abfall" in regard to the following points:

- multi-mineral base seal instead of a seal composed of only one type of clay.
- manageable and repairable Contrep® system
- double-layer plastic sealing membrane instead of single-layer plastic sealing membrane on a mineral seal.

Lucobit® sealing membranes have extremely high biaxial stretchability. Therefore, they adapt more easily to deformations on the base of a landfill caused by settling. This also enables a superior pressure bond between the mineral seal and plastic sealing membrane — important for an effective combination seal. Because of their formability, it is easier to lay these sealing membranes on the construction site than stiffer HDPE membranes.



Sealing of landfills

3.1.1.1 Contrep® sealing

The upper sealing layer of the multi-mineral base sealing with kaolinitic clay minerals provides a durable seal against seepage water. Kaolin is highly resistant to seepage water. The underlying expandable clay mineral sealing layer also serves as a sealing, but is able to filter and bind certain pollutants from the landfill seepage water, too.

Contrep® seals consist of two plastic sealing membranes. A 30 cm layer of coarse gravel and two 10 cm layers of protective sand are located between these membranes. The two membranes are connected every 50 m in both longitudinal and lateral directions by diagonally welded plastic webs to form air-tight sealing compartments.

This system is used at BASF's Flotzgrün landfill (near Heidelberg).

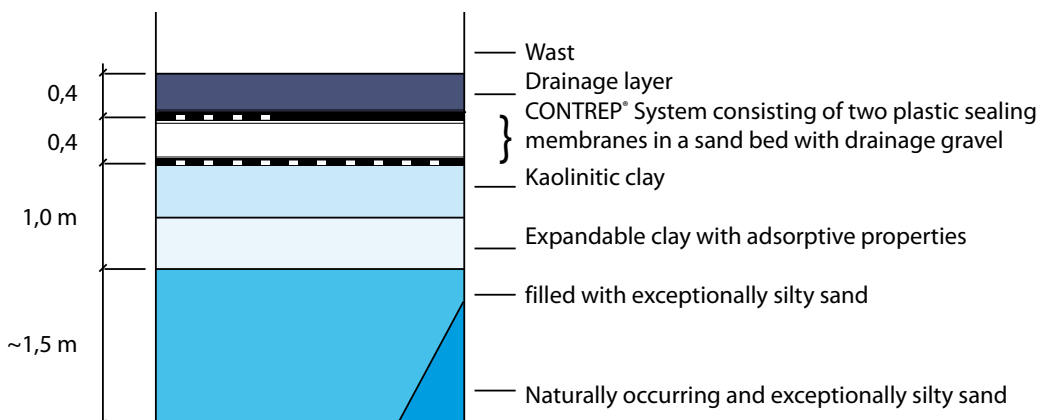

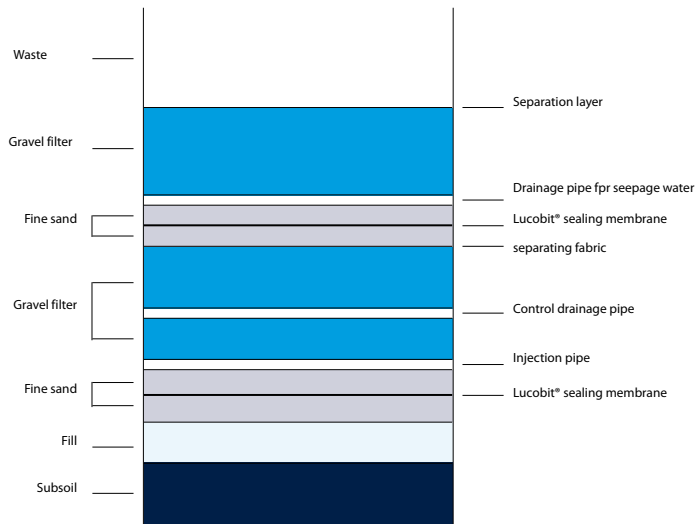

Layer structure

3.1.1.2 Schematic diagram of the base seal with telescopic shafts

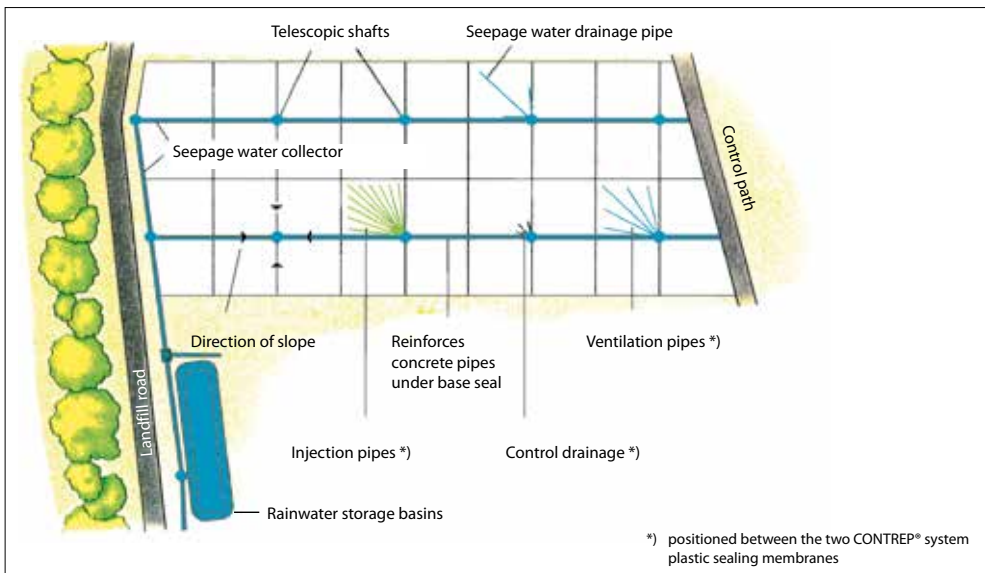

Telescopic shaft



Landfill surface sealing



3.1.1.3 Landfill surface sealing

The landfill surface needs to be sealed after filling the landfill to avoid endless maintenance due to the extensive seepage water, as well as to enable the discharge of the methane gas being produced. The cover should also make cultivation of the landfill surface possible. For hazardous waste landfills, "TA-Abfall" specifies that "the landfill surface sealing system shall be designed in such a way that leaks can be localized and repaired for as long as necessary".

LOCATIONS

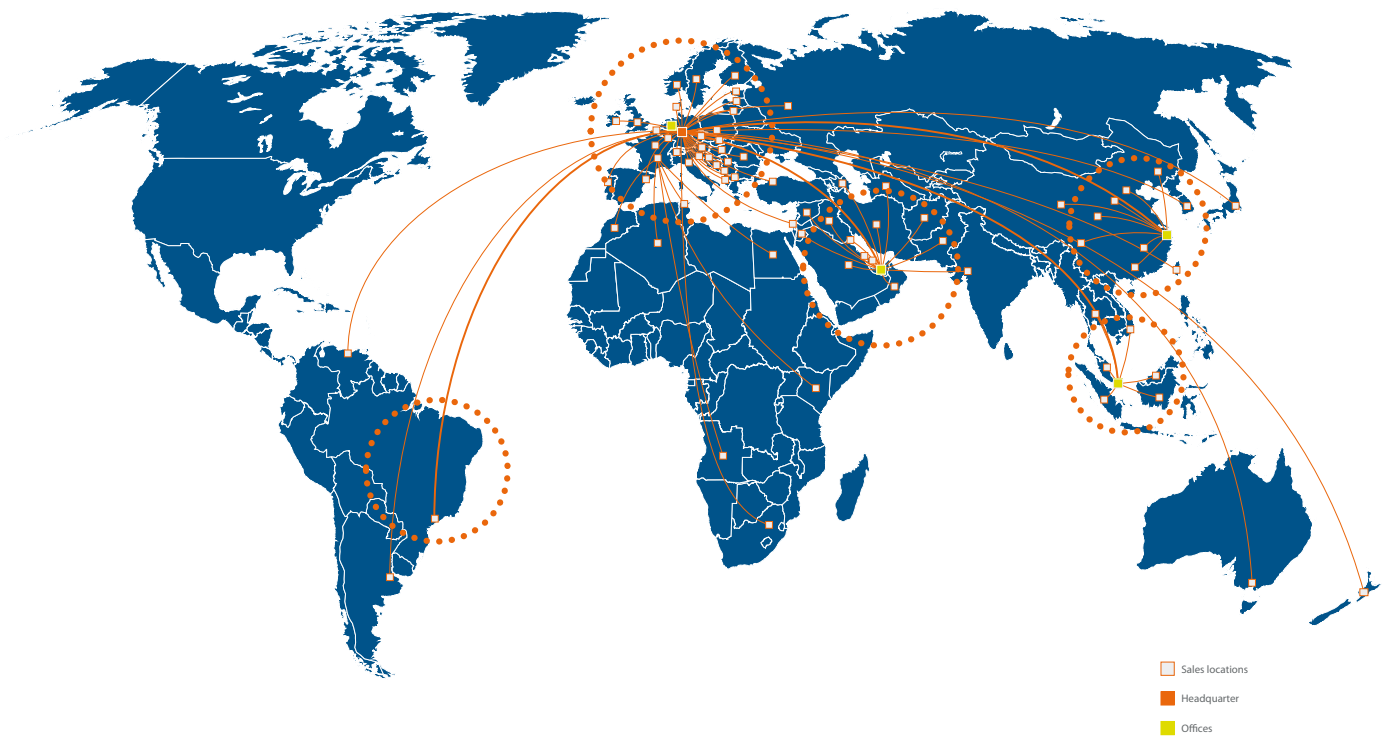

LUCOBIT Aktiengesellschaft
Basell Polyolefine GmbH / Brühler Str. 60 • B100
D-50389 Wesseling
Phone +49 2236 / 37859-0
Fax +49 2236 / 37859-99
info@lucobit.de
www.lucobit.com

Note
The information provided in this document is based on our product tests and present technical knowledge. It does not release purchasers from the responsibility of carrying out their receiving inspections. Neither does it imply any binding assurance of suitability of our products for a particular purpose. As LUCOBIT cannot anticipate or control the many different conditions under which this product may be processed and used this information does not relieve processors from their own tests and investigations. Any proprietary rights as well as existing legislation shall be observed.